

Ryterna TLP HL-TM SR Garage doors

Door parts list

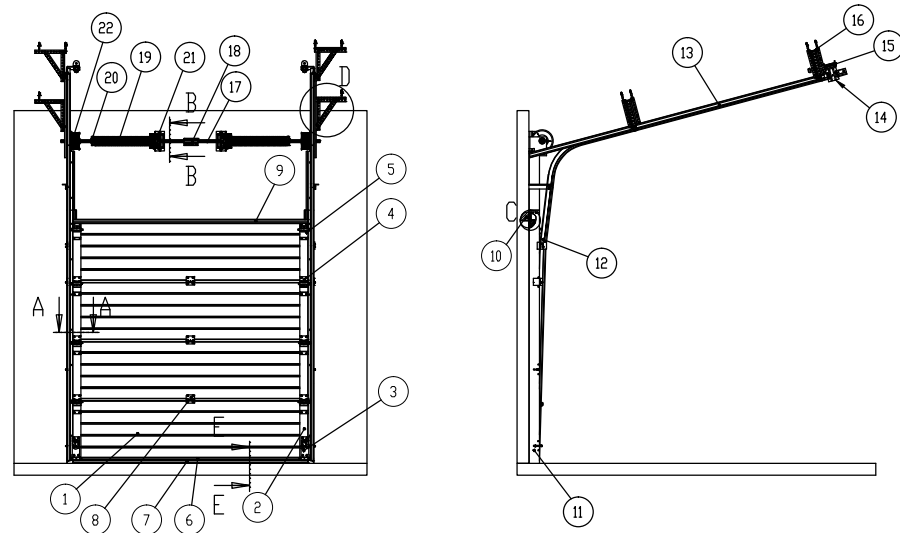

Nr.	Part
1	Sandwich panel
2	Panel endcap
3	Bottom roller bracket
4	Side roller bracket
5	Top roller bracket
6	Bottom profile
7	Bottom seal
8	Intermediate hinge
9	Top profile
10	Top seal
11	Vertical angle
12	Track
13	C profile
14	Corner for spring bumper
15	Spring bumper
16	Track fixing
17	Shaft
18	Aluminum coupler
19	Spring
20	Spring fitting
21	Spring break device
22	Drum

Door Cross-sections and detailed views

A-A(5:1)

Mounting types of vertical track profiles to a wall:

a) mounting to concrete or brick wall

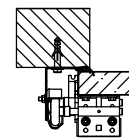

b) mounting to wood or steel tube

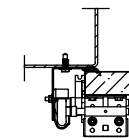

B-B(5:1)

Mounting types of spring bracket to a wall:

a) mounting to concrete or brick wall

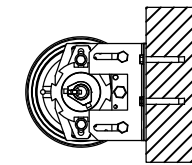

b) mounting to wood or steel tube

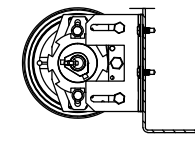

C(10:1)

Top seal place

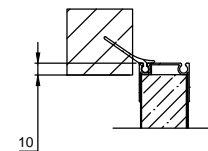

D(5:1)

Mounting types of horizontal tracks to a ceiling:

a) mounting to concrete

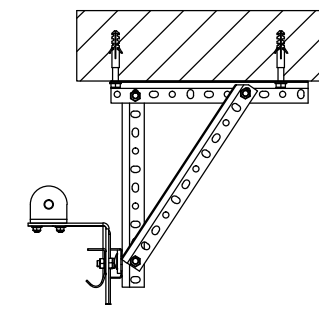

b) mounting to wood or steel tube

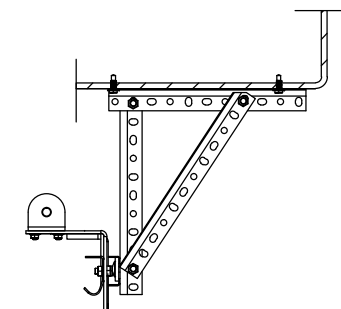

E(5:1)

Bottom seal and pass door step types:

a) No pass door

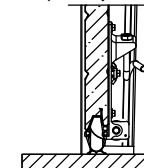

b) Standart step

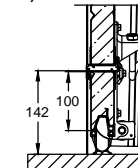

c) high step (for wide doors >6500)

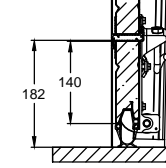

d) low doorstep

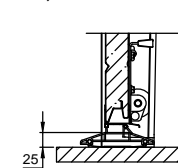

Space required for doors

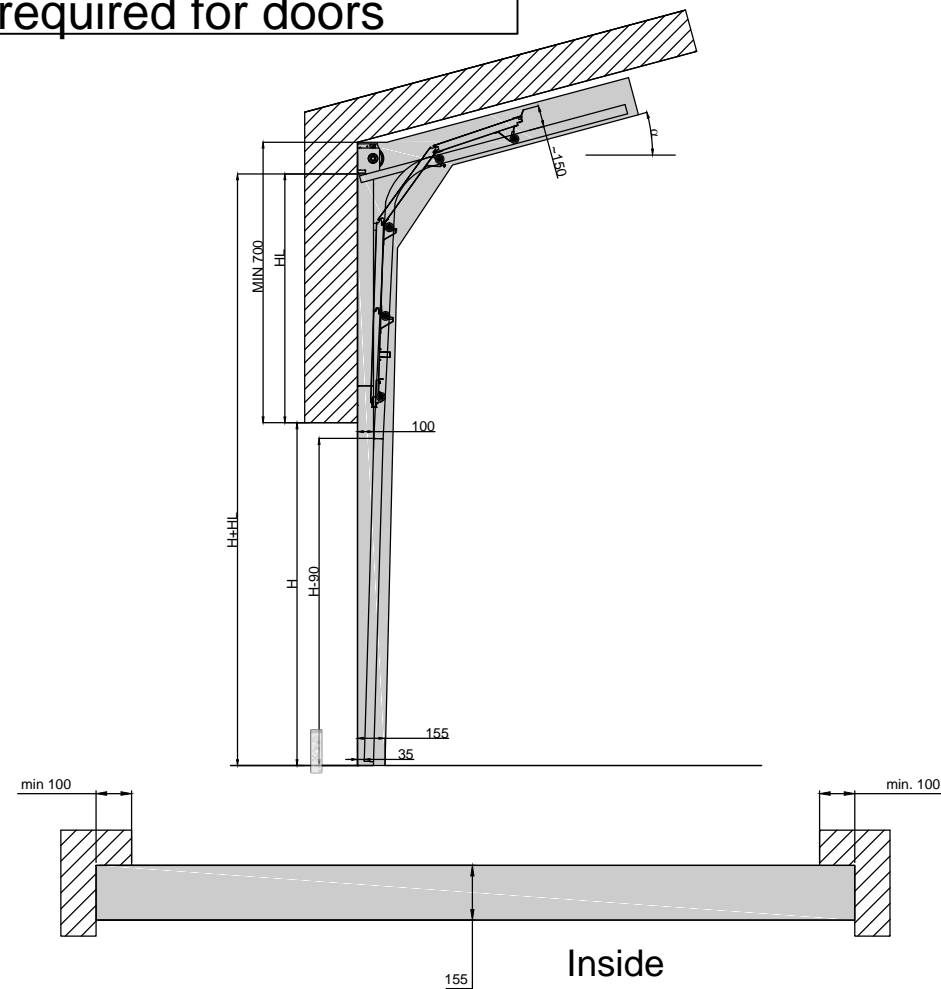

Ryterna Group

Tel.: +370 37 490990

www.Ryterna.eu

Drawn: Juozas Petrikas Date: 2016.06.29